

# USER MANUAL

## 600 & 900 // SLIDEOUT HOOD

### TS60SS | TS90SS

**IMPORTANT //** Please ensure that you read through this user manual prior to installation and use. This manual contains important information to ensure optimal performance and keep you safe. Please retain your proof of purchase, as this will be required in the event that you require warranty service. Remember to retain this manual for future reference.



# HELLO

**CONGRATULATIONS ON THE SELECTION OF THIS TISIRA APPLIANCE. TISIRA APPLIANCES HAVE BEEN SPECIFICALLY DESIGNED FOR AUSTRALIAN AND NEW ZEALAND KITCHENS.**

Please read through this user manual carefully as it contains information that will ensure that your appliance is installed correctly, important operating & care instructions and also some advice of what you need to do if this appliance is not performing as intended.

# CONTENTS

HELLO	2
CONTENTS	3
WARNING & SAFETY INFORMATION	4
INSTALLATION & DUCTING	5
OPERATING INSTRUCTIONS	7
MAINTAINING YOUR RANGEHOOD	8
PRODUCT SPECIFICATION	9
WARRANTY TERMS & CONDITIONS	10
PROOF OF PURCHASE	11
CONTACT DETAILS	12

# WARNING & SAFETY INFORMATION

- This appliance is not intended for use by persons (including children) with reduced physical, sensory or mental capabilities, or lack of experience and knowledge, unless they have been given supervision or instruction concerning use of the appliance by a person responsible for their safety.
- Young children should be supervised to ensure that they do not play with the appliance.
- There shall be adequate ventilation of the room when the rangehood is used at the same time as appliances burning gas or other fuels.
- You must read the details concerning the method and frequency of cleaning.
- There is a fire risk if cleaning is not carried out in accordance with the instructions.
- Do not flambé under the rangehood.
- Exhaust air must not be discharged into an existing flue which is used for exhausting fumes from appliances burning gas or other fuels.
- The minimum distance between the hob surface and the lowest part of the rangehood is 600mm. This distance shall be at least 650mm, if the rangehood is installed over a gas hob. If the instructions for the gas hob specify a greater distance, this has to be taken into account.
- Attention should be given to ensure that any applicable regulations concerning the discharge of exhaust air is fulfilled.
- If the supply cord of this equipment is damaged, it must only be replaced by the manufacturer or its service agent or a similarly qualified person in order to avoid a hazard.
- This appliance has been designed for indoor domestic use only.
- Do not remove or inspect the filters whilst the hood is in operation.

# INSTALLATION & DUCTING

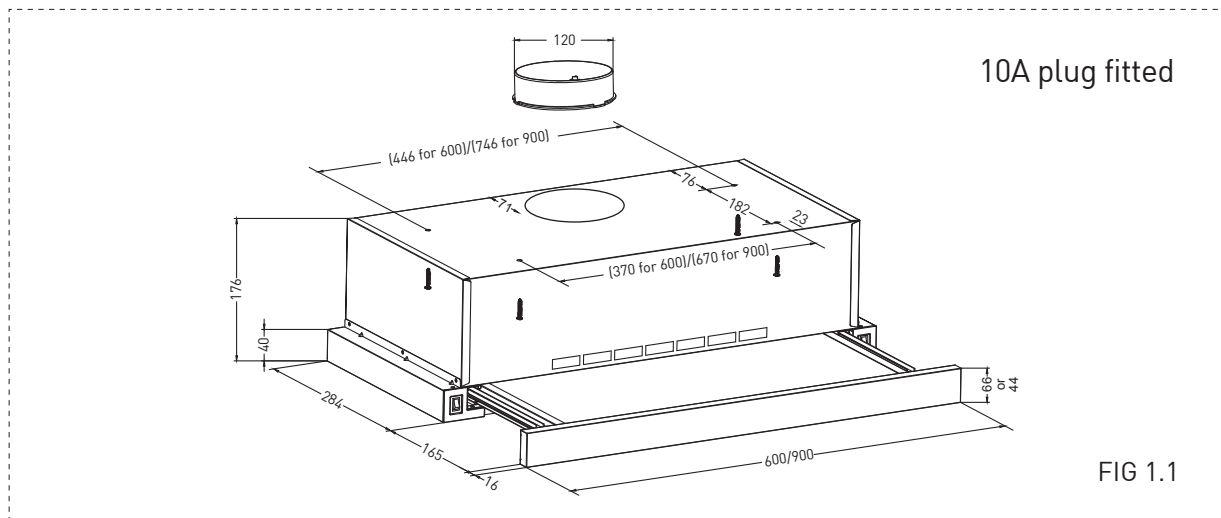

**IMPORTANT //** Before handling the rangehood during installation, it is recommended that you remove the filter to prevent damage

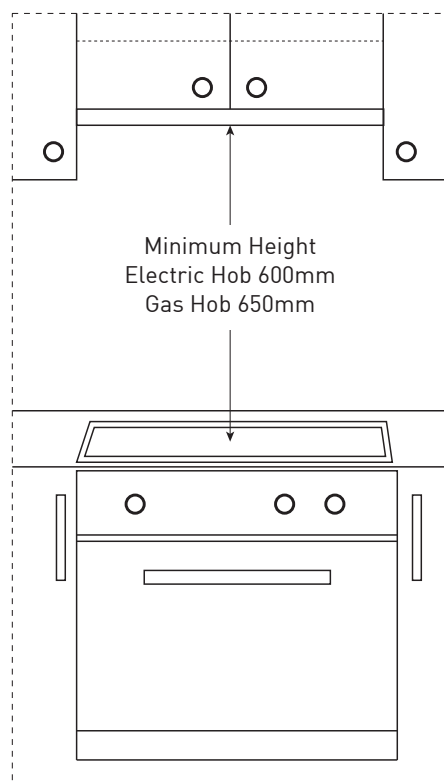
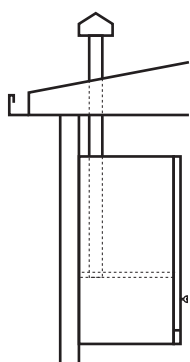

Fig 1.2 illustrates the minimum height from the hob surface to the underside of the rangehood. Electric hob – 600mm, Gas hob - 650mm.

**NOTICE //** IF THE INSTRUCTIONS FOR THE GAS HOB SPECIFY A GREATER DISTANCE, THIS HAS TO BE OBSERVED. ANY INSTALLATION ABOVE 750MM WILL COMPROMISE PERFORMANCE.

# INSTALLATION & DUCTING

## DUCTED OPTION



TOP DUCTING

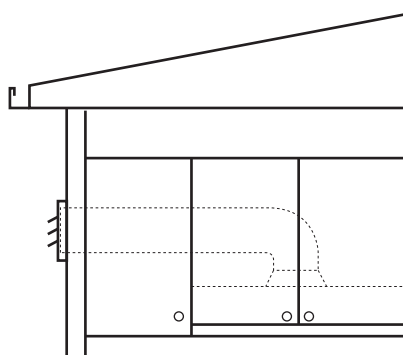

SIDE DUCTING

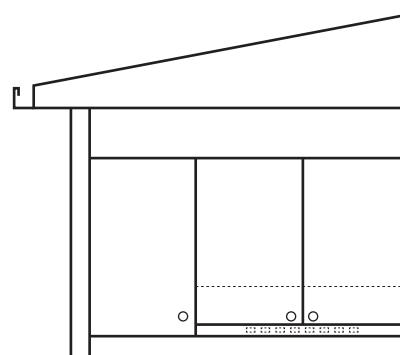

FRONT RE-CIRCULATING  
(Carbon filter required)

1. Remove the filter.
2. Replace the 65mm front rail with the 45mm front rail (include in box)
3. Determine the most efficient path for the ductwork, minimise bends and keep the length of the ductwork to a minimum.
4. Before fixing the range hood, drill a hole to accommodate the 120mm ducting that you have selected.
5. It is important to run and finish (install roof / wall caps) prior to installation of the hood.
6. Ensure that access has been allowed for the power cable.
7. Remove the 120mm ducting cover plate and attach the ducting adaptor.
8. Hold the hood up to the underside of the cabinet. Screw the rangehood to the underside of the cabinet. Ensure that you do not damage any of the wiring during installation.
9. Attach the ducting adaptor to the ducting.
10. Re-install filter.
11. Plug in the power to the unit, turn on and test.

## RE-CIRCULATING OPTION

**NOTICE // WHEN THE RANGEHOOD IS RE-CIRCULATING, CARBON FILTERS MUST BE INSTALLED.**

1. Remove the filter.
2. Remove the front sealing tape to expose the front vents. Do not remove the top 120mm outlet cover.
3. Drill 4 fixing holes as per the drawing. Ensure that access has been allowed for the power cable.
4. Hold the hood up to the underside of the cabinet; align the 4 holes in the cabinet with the corresponding holes in the hood. Screw the 4 screws from the cabinet side.
5. Re-install filter.
6. Plug in the power to the unit, turn on and test.

# OPERATING INSTRUCTIONS

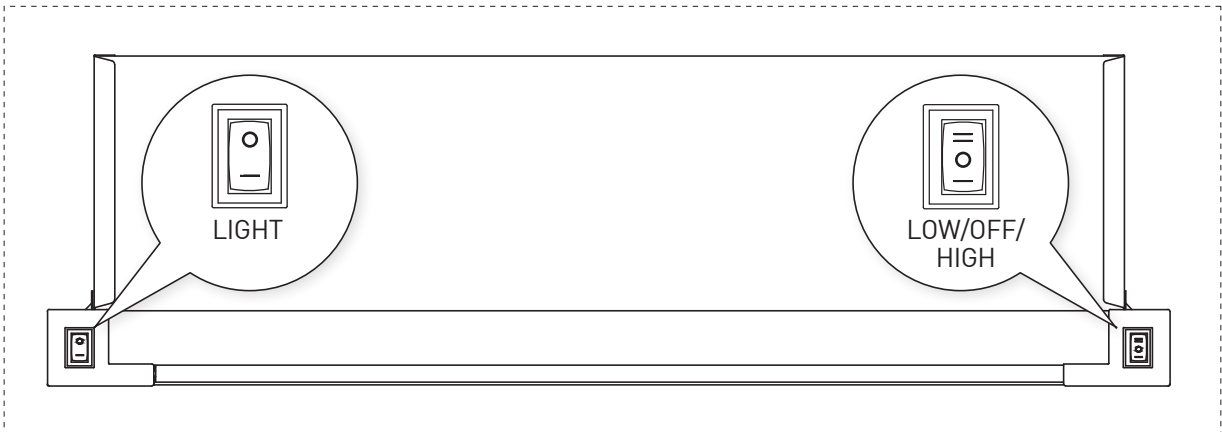

**IMPORTANT //** To operate the unit, ensure that the power is turned on and the front visor is fully extended (slide-out). This will provide access to the light and speed controls.

## FAN SPEED

LOW/OFF/HIGH switch - located on the right hand side of the unit.

This unit features 2 speed settings; single line indicate low speed, double lines indicate the high speed.

To turn the unit off, you can either slide the visor into the closed position or set the speed switch to the middle position (off).

## LIGHT

On/Off switch - located on the left hand side of the unit as indicated in the diagram above.

# MAINTAINING YOUR RANGEHOOD

## GENERAL MAINTENANCE

Ensure that the power to the unit is switched off prior to cleaning the unit. Surface should only be cleaned with warm soapy water and a soft non-abrasive cloth. In coastal environments and humid areas more frequent cleaning is required to maintain the finish.

## FILTERS

This unit is supplied with carbon filters designed to eliminate odours from your exhaust fumes. These filters cannot be cleaned and should be replaced every 3–6 months, dependant on use.

Aluminium filters may be ordered from your nearest service centre for ducted installations. Aluminium filters are dishwasher safe or can be cleaned with hot soapy water. Ensure that filters are thoroughly dry before re-installing.

## LAMPS

Your range hood is fitted with GU10 halogen lamps. Before replacing, ensure that lamps are completely cool and the power to the unit has been switched off. Replacement lamps can be purchased from your nearest service centre.

To remove the lamp, twist the lamp in an anti-clockwise direction. Be careful when installing the new lamp not to make contact with the skin as this may damage the lamp and shorten its life.



# PRODUCT SPECIFICATION



MODEL: TS60SS

SERIAL:

230V ~ 50Hz  
Total: 160W

Lights 2 x 20W  
Motor: 120W



ISS: 2306001

[www.tisira.com](http://www.tisira.com)

made in PRC

For service please call:  
Australia: 1300 762 219  
New Zealand: 09 306 1020



MODEL: TS90SS

SERIAL:

230V ~ 50Hz  
Total: 280W

Lights 2 x 20W  
Motor: 120W x 2



ISS: 2306002

[www.tisira.com](http://www.tisira.com)

made in PRC

For service please call:  
Australia: 1300 762 219  
New Zealand: 09 306 1020



# WARRANTY TERMS & CONDITIONS

**These Terms and Conditions apply only to Tisira products distributed in Australia and New Zealand by Arisit Pty Limited.**

1. This warranty applies for a period of 2 years parts and labour, Australia and New Zealand, commencing from date of purchase.
2. Evidence of the date of purchase must be shown to the technician, when he calls, to obtain benefit under this warranty.
3. This warranty applies only to the original purchaser/hire purchaser of this appliance and cannot be assigned or transferred. Failure to produce documentary proof of the date of original acquisition by the original purchaser will result in a charge being levied for work done, labour and parts supplied.
4. This warranty does not apply to:
  - a) Serviceable items such as filters, fuses, light bulbs, door seals, drive belts, external hoses, etc.
  - b) Damage to body work, paint work, glass, trivets and plastic items (such as, but not limited to windows, covers, baskets, trays, worktops, door handles, control and kick panels.)
  - c) Corrosion & rust damage.
  - d) Damages/blockages caused by laundry or foreign objects.

A fee for service will be charged following warranty claims where no fault is found with the appliance.
5. This warranty will not apply where:
  - a) The fault is caused by accident, misuse, oversuds, an infestation of vermin, fire, flood or the use of products not approved by Arisit Pty. Limited.
  - b) There has been a failure to comply, with the manufacturer's operating and installation instructions.
  - c) Service, modification or repair has been carried out by anybody other than an approved Tisira Service Technician.
  - d) The appliance has been used/installed anywhere other than a private dwelling, or where it has been used other than for domestic use.
  - e) The appliance is subject to a rental agreement.
6. Any defective part that has been replaced becomes the property of Arisit Pty Limited.
7. This warranty applies only to Tisira appliances purchased and installed in Australia and New Zealand.
8. Loss of use of the appliance or consequential loss of any nature is not covered.
9. A charge may be levied at the discretion of Arisit Pty Limited if the call is deemed unnecessary or if the cause of failure is traced to external sources such as, but not limited to: blown fuses, power failure, faulty installation, etc.
10. Where the appliance, the subject of a warranty claim or repair, is used or installed more than TWENTY (20) kilometres from the nearest Arisit Service Division or Authorised Service Agent, the cost of delivery to the nearest Service Division or travel costs for a technician or Authorised Service Agent shall be for the account of the Purchaser. Where a built-in appliance is located or installed outside the Arisit Authorised Service Agent's normal service area, additional travel and labour costs shall be the account of the Purchaser.
11. Arisit Pty Limited shall not under any circumstances be responsible in terms of this warranty for the replacement or repair of any part of the equipment which may have been damaged in transit, during and after installation or imperfections after installation.
12. Losses caused by act of God, failure to obtain spare parts, strikes or lockouts are not covered.
13. Service is offered during normal working hours only, also appliances to have clear access in a serviceable area.
14. This warranty does not effect your statutory rights.
15. Our goods come with guarantees that cannot be excluded under the Australian Consumer Law. You are entitled to a replacement or refund for a major failure and for compensation for any other reasonably foreseeable loss or damage. You are also entitled to have the goods repaired or replaced if the goods fail to be of acceptable quality and the failure does not amount to a major failure.

We reserve the right to amend any of the above without prior notice.

## Registration Form

To register for your warranty please complete and return this form to Arisit Pty Limited within 30 days of purchase.



Where did you first hear about Tisira?

- |   |  |
|---|--|
| <input type="checkbox"/> Advertising                  | <input type="checkbox"/> Tradesman's Recommendation        |
| <input type="checkbox"/> In Store Display             | <input type="checkbox"/> Recommendation by Friend/Relative |
| <input type="checkbox"/> Other (please specify) ..... |  |

Would you like any further information on other Tisira appliances? Please specify

- |                                      |                                  |
|--------------------------------------|----------------------------------|
| <input type="checkbox"/> Cooking     | <input type="checkbox"/> Laundry |
| <input type="checkbox"/> Dishwashers | <input type="checkbox"/> All     |

Please print in block letters

Date of Purchase    /    /

Mr     Mrs     Ms

Name of Retailer .....

.....  
Initials                      Surname

Address .....

Address .....

Model Number .....

State.....                      Postcode.....

Serial Number .....

Telephone.....

# PROOF OF PURCHASE

ATTACH YOUR PROOF OF PURCHASE  
FOR FUTURE REFERENCE

## CONTACT DETAILS

AUSTRALIA

### **ARISIT PTY LIMITED**

40-44 Mark Anthony Drive,  
Dandenong South, VIC 3175,  
Australia

P // 1300 762 219

F // 03 9768 0838

[consumer.care@arisit.com](mailto:consumer.care@arisit.com)

NEW ZEALAND

### **ARISIT PTY LIMITED**

PO Box 68-140  
Newton, Auckland 1145,  
New Zealand

P // 09 306 1020

F // 09 302 0077

[sales@aristonappliances.co.nz](mailto:sales@aristonappliances.co.nz)



TISIRA IS COMMITTED TO ONGOING RESEARCH AND DEVELOPMENT. EVERY EFFORT HAS BEEN MADE TO ENSURE ALL INFORMATION IN THIS USER MANUAL IS CORRECT AT TIME OF GOING TO PRINT. DIMENSIONS SHOULD BE USED AS A REFERENCE ONLY AND ACTUAL DIMENSIONS SHOULD BE TAKEN FROM THE PHYSICAL PRODUCT ONLY.

MANUFACTURER RESERVES THE RIGHT TO CHANGE SPECIFICATIONS WITHOUT NOTICE.

[www.tisira.com.au](http://www.tisira.com.au)

VERSION 1.0